

# LYNCS™

Weld inspection and corrosion mapping scanner

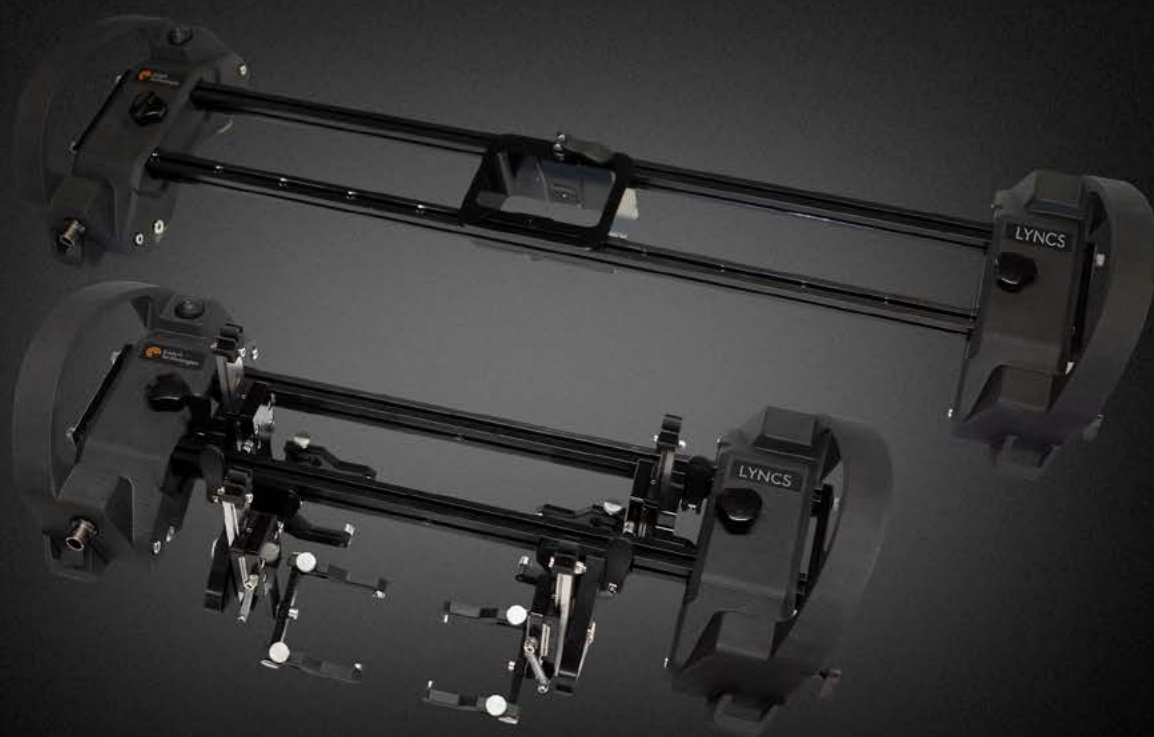

# WELD INSPECTION & CORROSION MAPPING SCANNER

Modular scanner for phased array corrosion mapping and weld inspection with up to six probes.

LYNCS™ is an advanced modular ultrasonic inspection scanner that has been designed by experts to provide Phased Array corrosion mapping and weld integrity assessment. It is the first truly versatile system that allows users to interchange between weld inspection and advanced corrosion mapping in less than 1 minute.

**LYNCS WI** weld inspection configuration can accommodate up to 6 PA and/or TOFD probes and has a dual-bar structure for enhanced stability and probe placement accuracy. It is a toolless scanner with an interchangeable design, making it ideally suited to all weld inspection configurations.

**LYNCS CM** corrosion mapping arrangement is ideally suited to vessel and pipework inspection. It has an extremely low profile and lightweight design, making it the most suitable option for rope access deployment and heavily congested pipework.

## Features

- Inspect assets from 100mm (4in) diameter.
- Quick and easy PAUT probe setup.
- Easily switch from corrosion mapping to weld inspection.
- Low profile for tightly spaced pipe racks 110mm (4.3in).
- Magnetic wheel to adhere to the inspection surface.
- Seamless integration with the M2M Gekko and M2M Mantis.
- Easily apply brakes to stop slippages.
- Onboard scanner controls for pause and index.
- Scalable solution for a variety of applications.
- Lightweight, ideal for rope access and tight spaces.

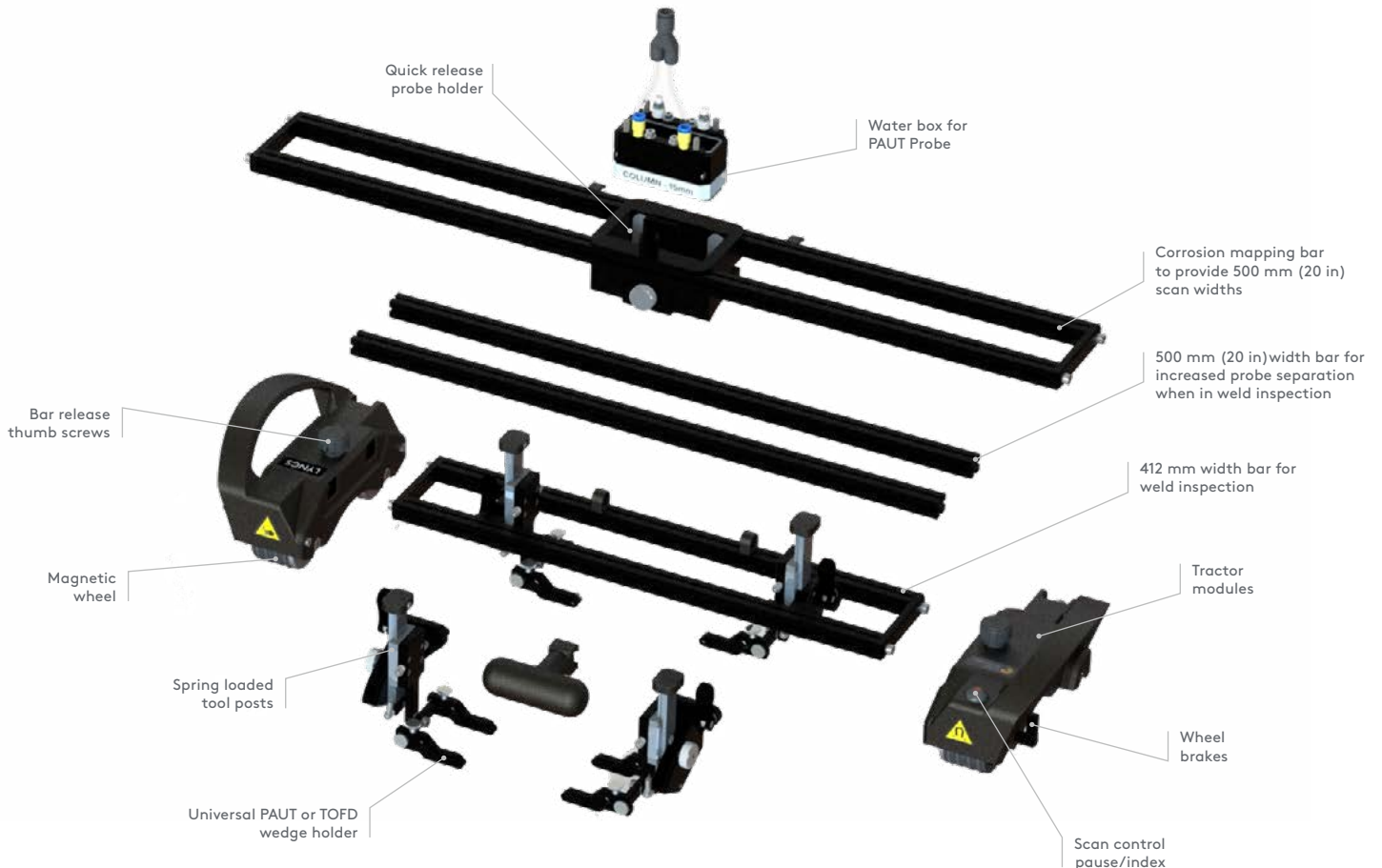

## LYNCS™ WI -Weld Inspection Configuration

### Applications

- Fabrication and in-service circumferential welds from 100mm (4in) to flat plate
- Pressure vessel circumferential welds
- Pipe to elbow/feature welds
- Storage tank/silo welds
- Crack detection, sizing & monitoring
- Corrosion/erosion detection & sizing



#### LYNCS WELD SPECIFICATIONS

Dimensions (w x d x h)	Short bar	487 x 198 x 109 mm (19.2 x 7.8 x 4.3 in)
	Medium bar	575 x 198 x 109 mm (22.6 x 7.8 x 4.3 in)
Bar width options	Short	412 mm (16.2 in)
	Medium	500 mm (19.7 in)
Maximum width of tool posts		40 mm (1.5 in)
Maximum number of tool posts		6
Tool posts compatibility		5mm male pin wedge.
		5mm female wedge
		8mm female wedge
Weight: scanner and	2 x tool posts	3 kg (6.6 lb)
	4 x tool posts	3.5 kg (7.7 lb)
	6 x tool posts	4 kg (8.8 lb)
Circumferential scanning		100 mm (4 in) to flat plate

#### COMMON ENVIRONMENTAL SPECIFICATIONS

Minimum surface temperature	-30°C (-22°F)
Maximum surface temperature	+80°C (176°F)
Minimum ambient temperature	-20°C (-4°F)
Maximum ambient temperature	+50°C (122°F)
Minimum storage temperature	-10°C (14°F)
Maximum storage temperature	+40°C (104°F)

## LYNCS CM -Corrosion Mapping Configuration

### Applications

- Pipework from 100mm (4in) to flat plate
- Vessel shell
- Storage, spherical, and silo tank shell
- Marine vessel hull
- Tank floors and ship decks
- Other critical assets



#### LYNCS CORROSION MAPPING SPECIFICATIONS

Dimensions (w x d x h)		742 x 198 x 109 mm (29.2 x 7.8 x 4.3 in)
Standard bar widths		412 mm (16.2 in) and 667 mm (26.2 in)
Maximum scan width		510 mm (20 in)
Scanner weight:	without water box	2.7 kg (6 lb)
	with water box	3.5 kg (7.7 lb)
Circumferential scanning		100 mm (4 in) to flat plate

#### WATER BOX SPECIFICATIONS

Water box mount external dimensions (w x d x h)	100 x 80 x H: 47 mm (3.9 x 3.1 x 1.8 in)
Water box mount internal dimensions (w x d x h)	82 x 42 x 47 mm (3.2 x 1.6 x 1.8 in)
Water box external dimensions (w x d x h)	81 x 41 x 57 mm (3.2 x 1.6 x 2.2 in)
Water box internal dimensions (w x d x h)	78 x 24 x 25 (3 x 0.9 x 1 in)

# LYNCS™ Packages

LYNCS FULL	LYNCS WI (WELD INSPECTION)	LYNCS CM (CORROSION MAPPING)
Scanner frame with 412mm (16 in) rails	Scanner frame with 412mm (16 in) rails	Scanner Frame with 412 mm (16 in) rails
2 x tractor units	2 x tractor units	2 x tractor units
4 tool posts	4 tool posts	667mm (26.2 in) metric rails with 50 mm drilled holes for increment step
500 mm (20 in) extended rails	500 mm (20 in) extended rails	676 mm (26.6 in) imperial rails with 2 in drilled holes for increment step
5 m (16 ft) or 15 m (48 ft) Umbilical	5 m (16 ft) or 15 m (48 ft) Umbilical	5 m (16 ft) or 15 m (48 ft) Umbilical
<b>Accessories</b> Tool case Wedge mounting pins kit Irrigation kit Removable central handle 8 x cable/hose guides 25 replacement seals	<b>Accessories</b> Tool case Wedge mounting pins kit Irrigation kit Removable central handle 8 x cable/hose guides	<b>Accessories</b> 8 x cable/hose guides 25 replacement seals
667mm (26.2 in) metric rails with 50 mm drilled holes for increment step	Transit case	Water box mount
676 mm (26.6 in) imperial rails with 2 in drilled holes for increment step		Water box
Water box mount		Transit case and portable site case
Water box		
Transit case and portable site case		

The information in this document is accurate as of its publication. Actual products may differ from those presented herein. © 2020 Eddyfi UK Ltd. Eddyfi, Silverwing, Lyncs, Gekko, Mantis and their associated logos are trademarks or registered trademarks of Eddyfi in the United States and/or other countries. Eddyfi reserves itself the right to change product offerings and specifications without notice. 27/08/20.